

# Installation Instruction

1

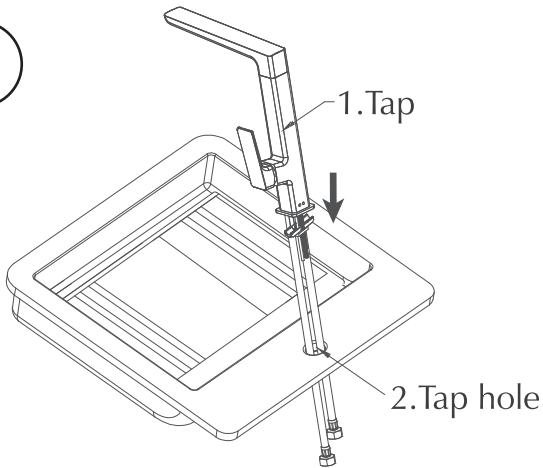

1. Leave the hoses connected to the tap, Insert the QBF and the hoses of the tap into the tap hole.

Note: Some tap holes may require the removal of the grey plastic socket used to tighten the hoses.

2

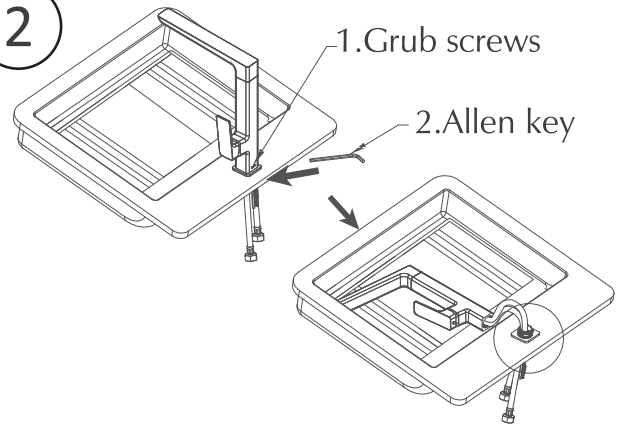

2. Loosen the grub screws to separate the tap from the QFB and rest the tap on provided cloth to avoid scratching.

3

Tighten the screw of the QFB

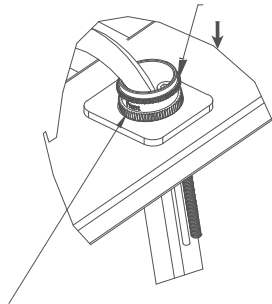

3. The QFB has a 'front' section labelled. Ensure this section is facing the front to avoid damaging or twisting the hoses.

Note: There are some situations the QFB can be turned to the side if required but you must ensure the hoses are not being damaged/twisted.

4

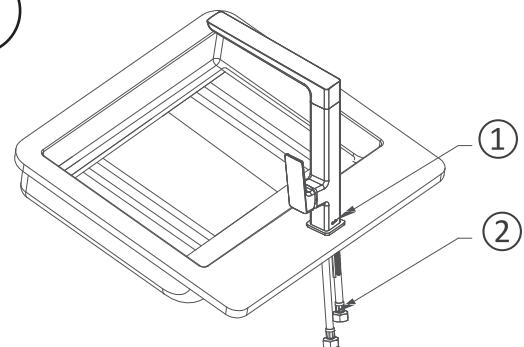

4.1. Adjust tap to the angle that faces the front and tighten the grub screws.  
4.2. Make sure the hoses are still tight as you connect them onto the wall water outlet.

Note: Ensure pipes are flushed from the mini-stops until the water is clean prior to connecting the hoses.



Please Note:

The Plumbing Code of Australia and the Australian Standards (AS/NZS 3500) require that water pressure on your property must not exceed 500kPa. Water mains pressure may be higher depending on where you live.

**This tap must be installed by a licenced plumber.**